

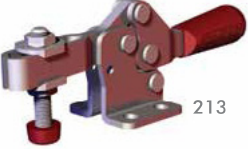

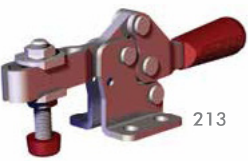



HORIZONTAL HOLD DOWN CLAMPS

Sizing and Application Chart



Series	Page MC-HHD-#	Max. Holding Capacity N [lbf.]						Height Under Clamping Bar mm [inch]												
		0 to 1000 [0 to 225]	1000 to 2000 [225 to 450]	2000 to 3000 [450 to 675]	3000 to 5000 [675 to 1125]	5000 to 7000 [1125 to 1575]	7000 to 10000 [1575 to 2250]	0 to 10 [0 to 0.39]	10 to 20 [0.39 to 0.79]	20 to 30 [0.79 to 1.18]	30 to 40 [1.18 to 1.57]	40 to 50 [1.57 to 1.97]	50 to 60 [1.97 to 2.36]	0 to 25 [0 to 0.98]	25 to 40 [0.98 to 1.57]	40 to 55 [1.57 to 2.17]	55 to 70 [2.17 to 2.76]	70 to 85 [2.76 to 3.35]	85 to 100 [3.35 to 3.94]	100+ [1.57+]
 2013	3		●					●						●						
	2017	5			●				●							●				
 213	2027	7				●				●							●			
	213	9		●					●											
 217	217	11	●	●						●										
	227	13			●					●							●			
 237	237	15				●					●						●			
	245	17										●								●
 205	205	19	●						●											
	215	21		●	●					●					●					
 225	225	23			●						●					●				
	235	25				●						●					●			
 305	305	27	●						●						●					
	307	27		●						●							●			
 309	309	27				●					●									●
	206	29	●												●					
 5310	5305	31			●					●					●					
	5310	31								●						●				

HORIZONTAL HOLD DOWN CLAMPS

Sizing and Application Chart

Overall Length mm [inch]								Overall Width mm [inch]				Suitable Application Areas								Standard Material		Arm Style		Mounting Style		Service Environment					
50 to 75 [1.97 to 2.95]	75 to 100 [2.95 to 3.94]	100 to 125 [3.94 to 4.92]	125 to 150 [4.92 to 5.91]	150 to 175 [5.91 to 6.89]	175 to 200 [6.89 to 7.87]	200 to 225 [7.87 to 8.86]	225 to 250 [8.86 to 9.84]	250+ [9.84+]	0 to 25 [0 to 0.98]	25 to 40 [0.98 to 1.57]	40 to 55 [1.57 to 2.17]	55 to 70 [1.57 to 2.76]	Welding	Assembly	Checking Fixtures	Machining	Woodworking	Closures	Food Processing	Duty Cycle	Steel	Stainless Steel	Toggle Lock Plus	U-Bar Version	Solid Arm Version	Straight Base	Flanged Base	Welded	Normal	Harsh/Dirty	
			●										○	●	●	●	●	●	⊗	○	✓		✓	✓		✓			✓	✓	
						●				●			○	●	●	●	●	●	⊗	○	✓		✓	✓			✓			✓	✓
							●			●			○	●	●	○	●	●	⊗	○	✓		✓	✓			✓			✓	✓
			●										○	●	●	●	●	●	○	○	✓	✓		✓	✓		✓			✓	✓
				●						●			○	●	●	●	●	●	○	○	✓	✓		✓	✓		✓			✓	✓
							●						○	●	●	●	●	●	○	○	✓	✓		✓	✓		✓			✓	✓
●									●				○	●	○	○	●	●	○	○	✓	✓	✓	✓			✓			✓	✓
●	●									●			○	●	○	○	●	●	○	○	✓		✓	✓			✓			✓	✓
●			●								●		○	●	○	○	○	○	○	○	✓	✓	✓	✓			✓			✓	✓
						●							○	●	○	○	○	○	⊗	○	✓		✓				✓			✓	✓
							●						○	●	○	○	○	○	⊗	○	✓		✓				✓			✓	✓

● Excellent/High ○ Fair/Medium ● Poor/Low ⊗ Not Recommended

2013 SERIES

Horizontal Hold Down Clamps | Product Overview

Features:

- Increased handle clearance reduces pinch points
- Common mounting hole pattern to Model 213
- Fixed handle pivot provides smooth action
- Nearly 2 times the holding capacity Model 213
- BLK models feature a black, non-reflective finish

Applications:

- Checking fixtures
- Assembly & test
- Light machining
- Woodworking
- Closures

Also Available:

See page MC-ACC-1 for accessories
Accommodates M5 or #10 spindle accessory

Covered under one or more U.S./International Patents

2013-U
Flanged Base
U-Bar



2013-U-LS-BLK ⓘ
Blackout Series
Flanged Base, U-Bar



2013-UR
Flanged Base, U-Bar
with DESTACO®
Toggle Lock
Plus



ⓘ This item is available upon request

Technical Information

Model	Max. Holding Capacity	Clamp Bar Opening (+10°)	Handle Opening (+10°)	Weight	Accessories (Supplied)	
					Spindle Assembly	Flanged Washers
2013-U	1310 N [295 lbf]	71°	58°	0,17kg [0.37lb]	2013208-M	102111
2013-U-LS-BLK ⓘ					--	102111-BLK
2013-UR					2013208-M	102111

ⓘ This item is available upon request

Holding Capacities

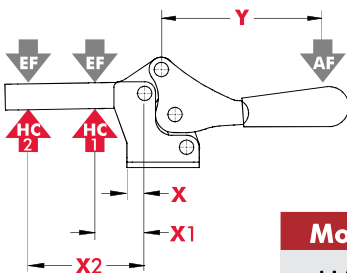

Model	X	X1	X2	Y	±HC1	±HC2	±EF(X1):AF	±EF(X2):AF
U/UR	[0.63] 16	[0.95] 24	[1.95] 49,5	[2.34] 59,5	[295lbf.] 1310N	[175lbf.] 780N	6:1	4:1

Dimensions shown "mm [inch]" ± HC = Holding Capacity, EF = Exerting Force, AF = Applied Force
See page MC-TEC-4 for additional information.



2013 SERIES

Horizontal Hold Down Clamps | Dimensions | -U/-UR

2013-U
Flanged Base
U-Bar

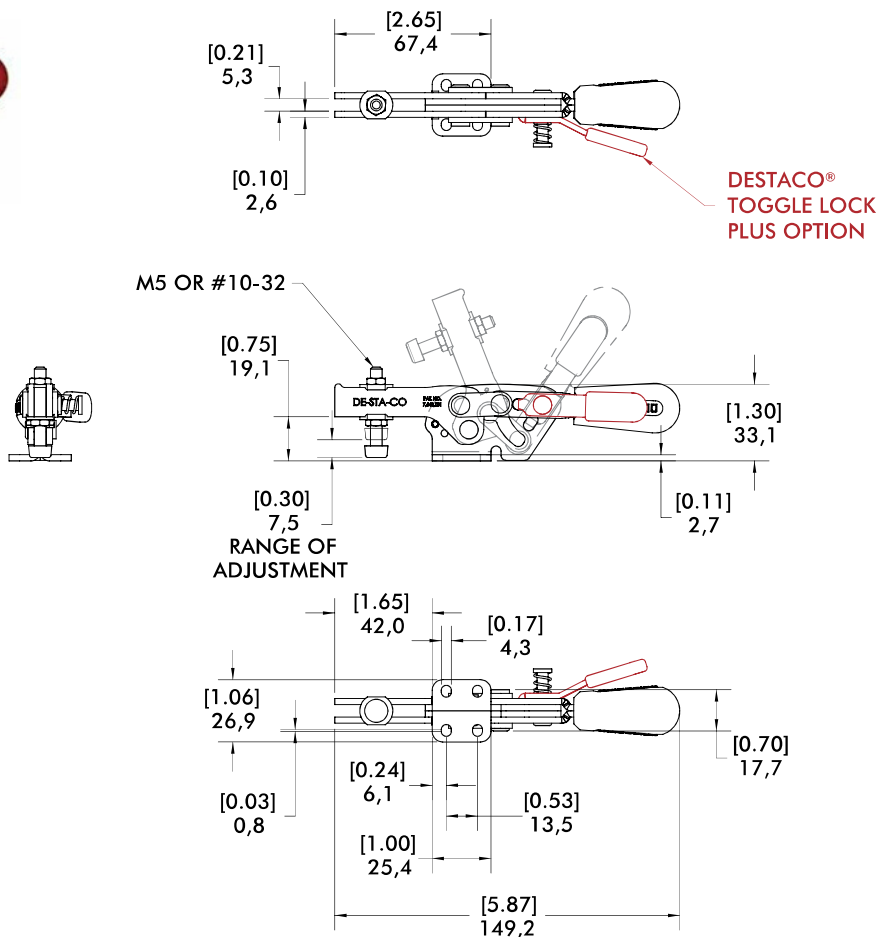

2017 SERIES

Horizontal Hold Down Clamps | Product Overview

Features:

- Increased handle clearance reduces pinch points
- Common mounting hole pattern to Model 217
- Fixed handle pivot provides smooth action
- Over 2½ times the holding capacity Model 217
- BLK models feature a black, non-reflective finish

Applications:

- Checking fixtures
- Assembly & test
- Light machining
- Woodworking
- Closures

Also Available:

See page MC-ACC-1 for accessories

Accommodates M6 or ¼" spindle accessory

Covered under one or more U.S./International Patents

2017-U
Flanged Base
U-Bar



2017-U-LS-BLK ⓘ
Blackout Series
Flanged Base
U-Bar



2017-UR
Flanged Base, U-Bar
with DESTACO®
Toggle Lock
Plus



ⓘ This item is available upon request

Technical Information

Model	Max. Holding Capacity	Clamp Bar Opening (+10°)	Handle Opening (+10°)	Weight	Accessories (Supplied)	
					Spindle Assembly	Flanged Washers
2017-U	2500 N [560 lbf]	73°	69°	0,44kg [0.97lb]	215208-M	215105
2017-U-LS-BLK ⓘ					--	215105-BLK
2017-UR					215208-M	215105

ⓘ This item is available upon request

Holding Capacities

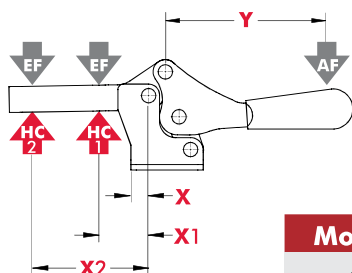

Model	X	X1	X2	Y	±HC1	±HC2	±EF(X1):AF	±EF(X2):AF
U/UR	[1.08] 27,4	[1.65] 42	[3.15] 80	[2.54] 64,5	[560lbf.] 2500N	[245lbf.] 1090N	5:1	2.5:1

Dimensions shown "mm [inch]" ± HC = Holding Capacity, EF = Exerting Force, AF = Applied Force
See page MC-TEC-4 for additional information.



2017 SERIES

Horizontal Hold Down Clamps | Dimensions | -U/-UR

2017-U
Flanged Base
U-Bar

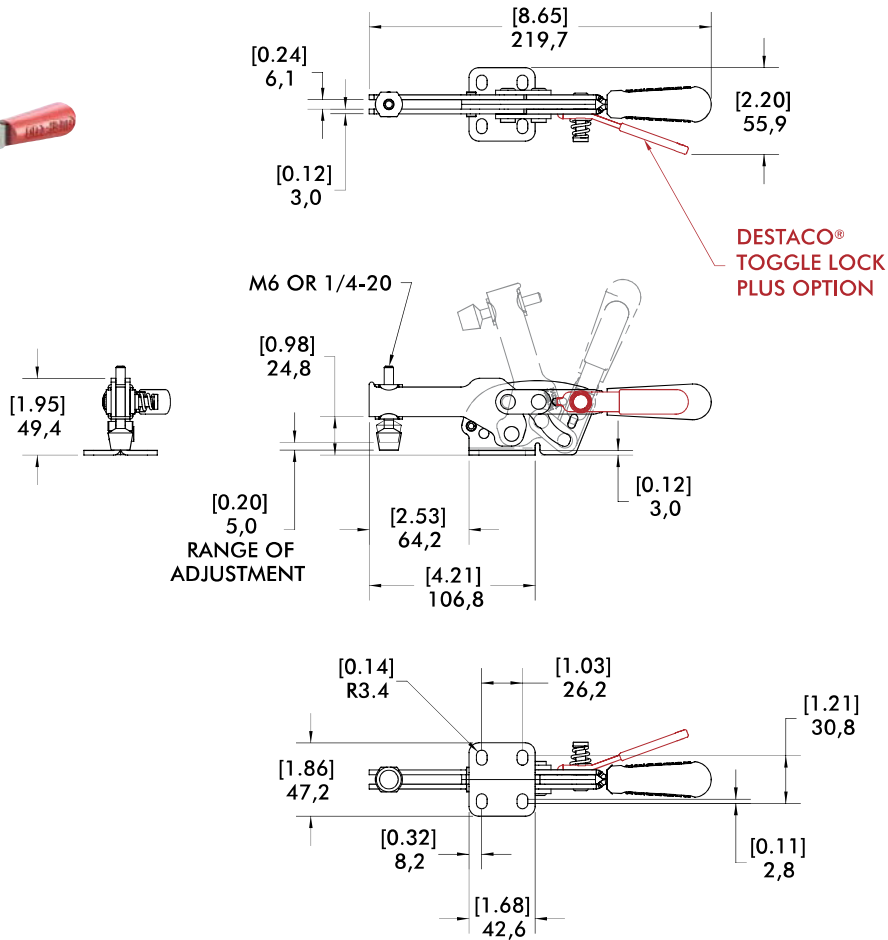

2027 SERIES

Horizontal Hold Down Clamps | Product Overview

Features:

- Increased handle clearance reduces pinch points
- Common mounting hole pattern to Model 227
- Fixed handle pivot provides smooth action
- Over 1 ½ times the holding capacity Model 227
- BLK models feature a black, non-reflective finish

Applications:

- Checking fixtures
- Assembly & test
- Light machining
- Woodworking
- Closures

Also Available:

See page MC-ACC-1 for accessories
Accommodates M8 or 5/16" spindle accessory

Covered under one or more U.S./International Patents

2027-U

Flanged Base
U-Bar



2027-U-LS-BLK ⓘ

Blackout Series
Flanged Base
U-Bar



2027-UR

Flanged Base, U-Bar
with DESTACO®
Toggle Lock
Plus



ⓘ This item is available upon request

Technical Information

Model	Max. Holding Capacity	Clamp Bar Opening (+10°)	Handle Opening (+10°)	Weight	Accessories (Supplied)	
					Spindle Assembly	Flanged Washers
2027-U					2007208-M	507107
2027-U-LS-BLK ⓘ	3740 N [840 lbf]	68°	70°	0,61 kg [1.34lb]	--	507107-BLK
2027-UR					2007208-M	507107

ⓘ This item is available upon request

Holding Capacities

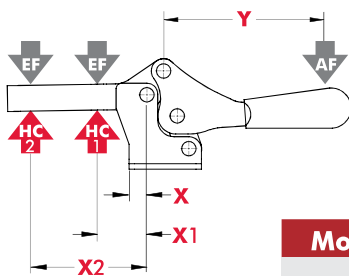

Model	X	X1	X2	Y	±HC1	±HC2	±EF(X1):AF	±EF(X2):AF
U/UR	[1.02] 25,8	[1.75] 44,5	[3.30] 83,8	[2.54] 64,5	[840lbf.] 3740N	[480lbf.] 2140N	5:1	3:1

Dimensions shown "mm [inch]" ± HC = Holding Capacity, EF = Exerting Force, AF = Applied Force
See page MC-TEC-4 for additional information.



2027 SERIES

Horizontal Hold Down Clamps | Dimensions | -U/-UR

2027-U
Flanged Base
U-Bar

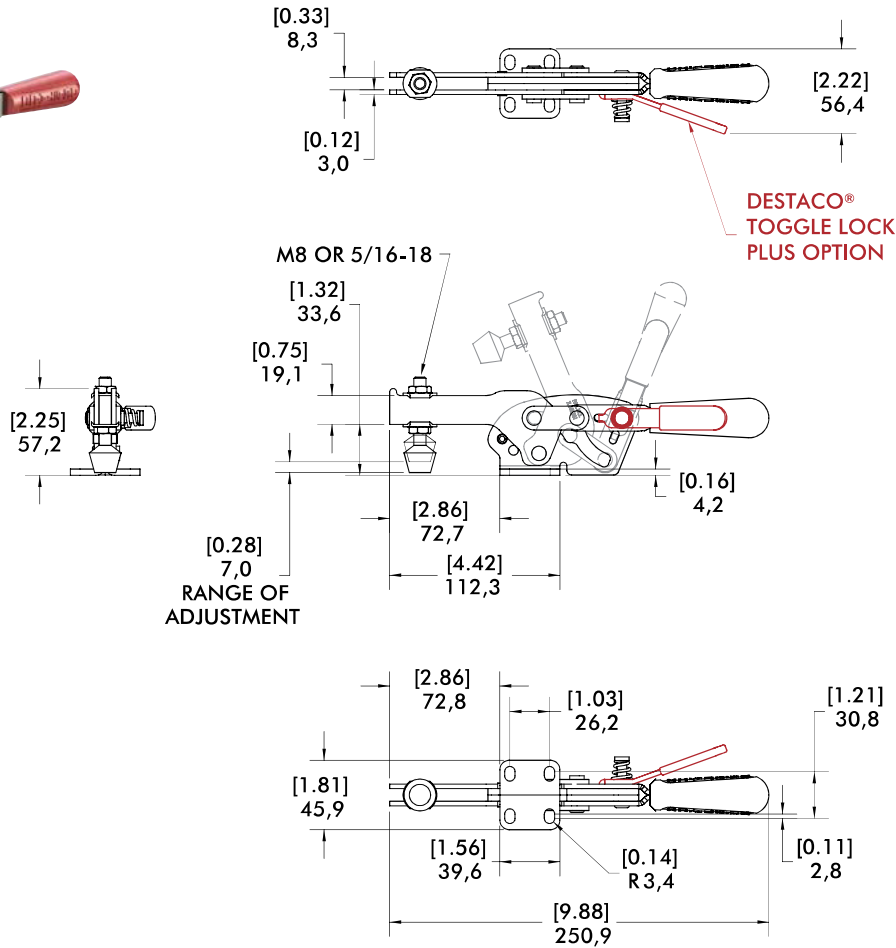

213 SERIES

Horizontal Hold Down Clamps | Product Overview

Features:

- Low profile
- Large handle clearance in the open position
- Available in stainless steel
- BLK models feature a black, non-reflective finish

Applications:

- Assembly
- Checking fixtures
- Closures
- Woodworking

Also Available:

See page MC-ACC-1 for accessories

Accommodates M5 or #10 spindle accessory

213-U

Flanged Base U-Bar



213-U-LS-BLK ⓘ

Blackout Series Flanged Base U-Bar



213-USS

Flanged Base U-Bar, Stainless Steel

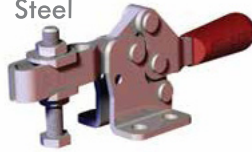

213-UB

Straight Base U-Bar



213-UB-LS-BLK ⓘ

Blackout Series Straight Base U-Bar



213-U-L ⓘ

Flanged Base Open Bar



213-U-L-BLK ⓘ

Blackout Series Flanged Base Open Bar



213-UB-L ⓘ

Straight Base Open Bar



213-UB-L-BLK ⓘ

Blackout Series Straight Base Open Bar



ⓘ This item is available upon request

Technical Information

Model	Max. Holding Capacity	Clamp Bar Opening (+10°)	Handle Opening (+10°)	Weight	Accessories (Supplied)	
					Spindle Assembly	Flanged Washers
213-U	670 N [150 lbf]	90°	60°	0,08kg [0.17lb]	213208-M	102111
213-U-LS-BLK ⓘ					--	102111-BLK
213-USS					201943-M	102911
213-UB					213208-M	102111
213-UB-LS-BLK ⓘ					--	102111-BLK
213-U-L ⓘ					--	102111
213-U-L-BLK ⓘ					--	102111-BLK
213-UB-L ⓘ					--	102111
213-UB-L-BLK ⓘ					--	102111-BLK

ⓘ This item is available upon request

213 SERIES

Horizontal Hold Down Clamps | Holding Capacities

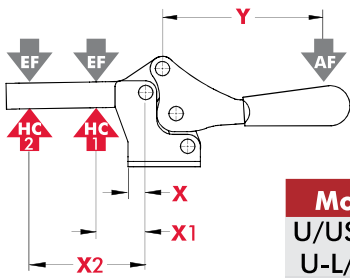

Model	X	X1	X2	Y	±HC1	±HC2	±EF(X1):AF	±EF(X2):AF
U/USS/UB	[0.36]	[0.75]	[1.63]	[1.81]	[150lbf.]	[70lbf.]	7:1	3:1
U-L/UB-L	9,3	19	41,4	46	670N	310N		

Dimensions shown "mm [inch]" ± HC = Holding Capacity, EF = Exerting Force, AF = Applied Force
See page MC-TEC-4 for additional information.

Dimensions | -U/-USS/-UB

213-U
Flanged Base
U-Bar

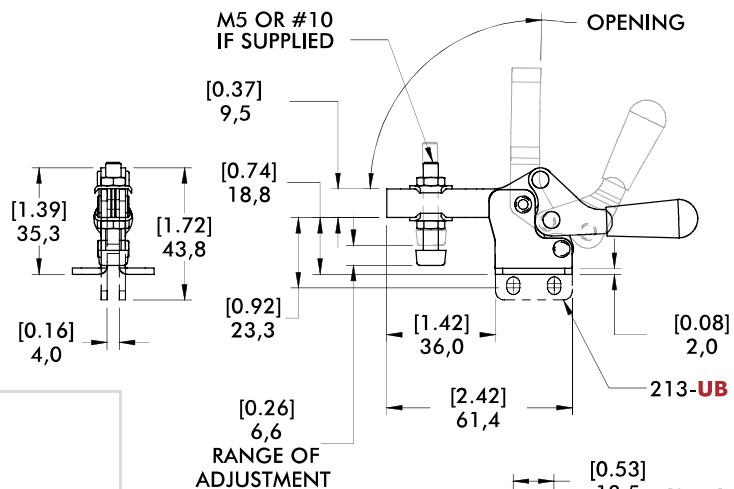
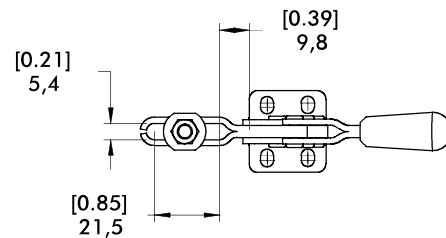

Series 213 Open Bar Options



Flanged Base
Model
213-U-L

See page MC-ACC-7 for Complete offering of Open bar accessories

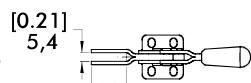

Straight Base
Model
213-UB-L

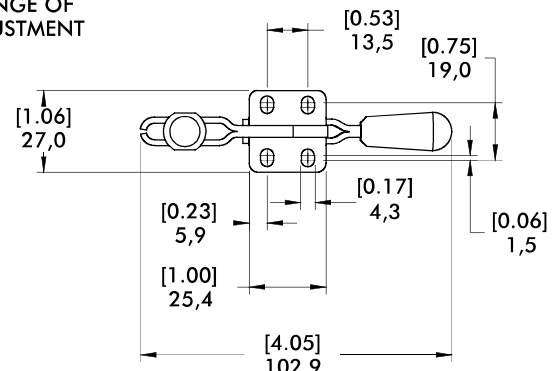
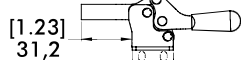

mm [INCH]
THIRD ANGLE PROJECTION

Dimensions and technical information are subject to change without notice

MC-HHD | 10



217 SERIES

Horizontal Hold Down Clamps | Product Overview

Features:

- Low profile
- Large handle clearance in the open position
- Available in stainless steel
- BLK models feature a black, non-reflective finish

Applications:

- Assembly
- Checking fixtures
- Closures
- Woodworking

Also Available:

See page MC-ACC-1 for accessories

Accommodates M6 or 1/4" spindle accessory

217-U

Flanged Base U-Bar



217-U-LS-BLK ⓘ

Blackout Series Flanged Base U-Bar



217-USS

Flanged Base U-Bar, Stainless Steel

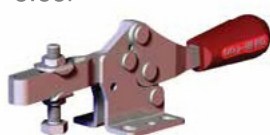

217-UB

Straight Base U-Bar



217-UB-LS-BLK ⓘ

Blackout Series Straight Base U-Bar



217-U-L ⓘ

Flanged Base Open Bar



217-U-L-BLK ⓘ

Blackout Series Flanged Base Open Bar



217-UB-L ⓘ

Straight Base Open Bar



217-UB-L-BLK ⓘ

Blackout Series Straight Base Open Bar



ⓘ This item is available upon request

Technical Information

Model	Max. Holding Capacity	Clamp Bar Opening (+10°)	Handle Opening (+10°)	Weight	Accessories (Supplied)		
					Spindle Assembly	Flanged Washers	
217-U	900 N [200 lbf]	91°	61°	0,18kg [0.40lb]	202208-M	215105	
217-U-LS-BLK ⓘ					--	215105-BLK	
217-USS	1110 N [250 lbf]				202943-M	215105	
217-UB					202208-M	215105	
217-UB-LS-BLK ⓘ						215105-BLK	
217-U-L ⓘ	900 N [200 lbf]					215105	
217-U-L-BLK ⓘ						--	215105-BLK
217-UB-L ⓘ							215105
217-UB-L-BLK ⓘ				215105-BLK			

ⓘ This item is available upon request

217 SERIES

Horizontal Hold Down Clamps | Holding Capacities

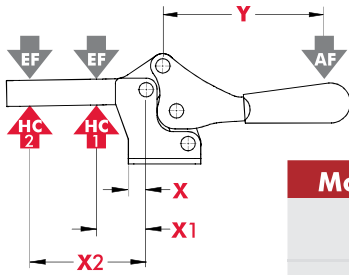

Model	X	X1	X2	Y	±HC1	±HC2	±EF(X1):AF	±EF(X2):AF
U					[200lbf.] 900N	[80lbf.] 360N		
USS	[0.53] 13,5	[1.13] 28,6	[2.63] 66,8	[2.93] 74,5	[250lbf.] 1110N	[100lbf.] 440N	7:1	3:1
UB/U-L/ UB-L					[200lbf.] 900N	[80lbf.] 360N		

Dimensions shown "mm [inch]" ± HC = Holding Capacity, EF = Exerting Force, AF = Applied Force
See page MC-TEC-4 for additional information.

Dimensions | -U/-USS/-UB

Series 217 Open Bar Options



Flanged Base
Model
217-U-L ⓘ



Straight Base
Model
217-UB-L ⓘ

See page MC-ACC-7 for
Complete offering of
Open bar accessories

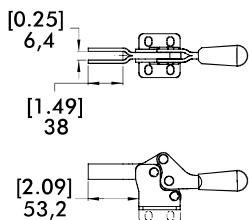

217-U Flanged Base U-Bar

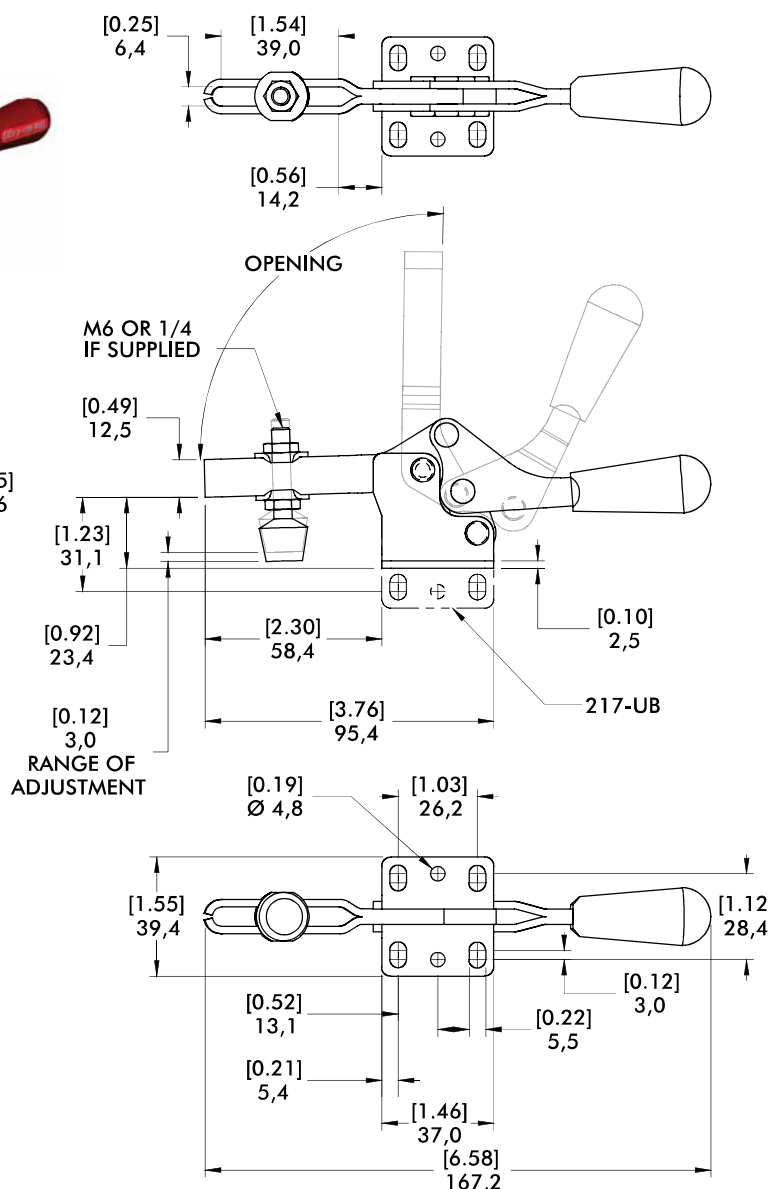
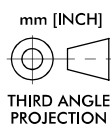
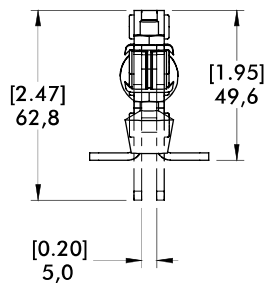

227 SERIES

Horizontal Hold Down Clamps | Product Overview

Features:

- Low profile
- Large handle clearance in the open position.
- Available in stainless steel
- BLK models feature a black, non-reflective finish

Applications:

- Assembly
- Checking fixtures
- Closures
- Woodworking

Also Available:

See page MC-ACC-1 for accessories

Accommodates M6 or 5/16" spindle accessory

227-U
Flanged Base
U-Bar



227-U-LS-BLK ⓘ
Blackout Series
Flanged Base
U-Bar



227-USS
Flanged Base
U-Bar, Stainless
Steel



227-UB
Straight Base
U-Bar



227-UB-LS-BLK ⓘ
Blackout Series
Straight Base
U-Bar



227-U-L ⓘ
Flanged Base
Open Bar



227-U-L-BLK ⓘ
Blackout Series
Flanged Base
Open Bar



227-UB-L ⓘ
Straight Base
Open Bar



227-UB-L-BLK ⓘ
Blackout Series
Straight Base
Open Bar



ⓘ This item is available upon request

Technical Information

Model	Max. Holding Capacity	Clamp Bar Opening (+10°)	Handle Opening (+10°)	Weight	Accessories (Supplied)	
					Spindle Assembly	Flanged Washers
227-U	2220 N [500 lbf]	91°	56°	0,31 kg [0.68lb]	225208-M	507107
227-U-LS-BLK ⓘ					--	507107-BLK
227-USS	2670 N [600 lbf]				-207943-M	507907
227-UB	2220 N [500 lbf]				225208-M	507107
227-UB-LS-BLK ⓘ					--	507107-BLK
227-U-L ⓘ	--				507107	
227-U-L-BLK ⓘ	--				507107-BLK	
227-UB-L ⓘ	--				507107	
227-UB-L-BLK ⓘ	--	507107-BLK				

ⓘ This item is available upon request

227 SERIES

Horizontal Hold Down Clamps | Holding Capacities

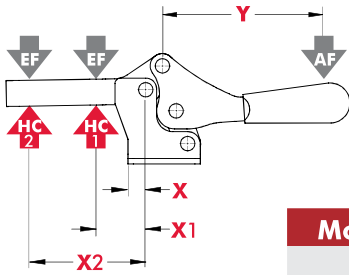

Model	X	X1	X2	Y	±HC1	±HC2	±EF(X1):AF	±EF(X2):AF
U					[500lbf.] 2220N	[225lbf.] 1000N		
USS	[0.39] 10,0	[1.25] 31,8	[2.75] 70,0	[3.58] 91,0	[600lbf.] 2670N	[270lbf.] 1200N	8:1	3:1
UB/U-L/ UB-L					500lbf.] 2220N	[225lbf.] 1000N		

Dimensions shown "mm [inch]" ± HC = Holding Capacity, EF = Exerting Force, AF = Applied Force
See page MC-TEC-4 for additional information.

Dimensions | -U/-USS/-UB

227-U
Flanged Base
U-Bar

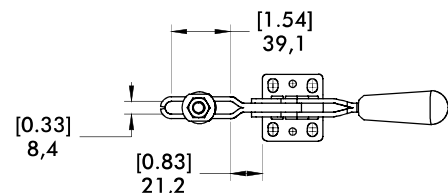

Series 227 Open Bar Options



Flanged Base
Model
227-U-L

See page MC-ACC-7 for Complete offering of Open bar accessories

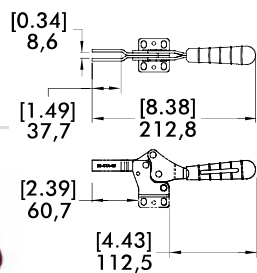

Straight Base
Model
227-UB-L

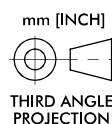
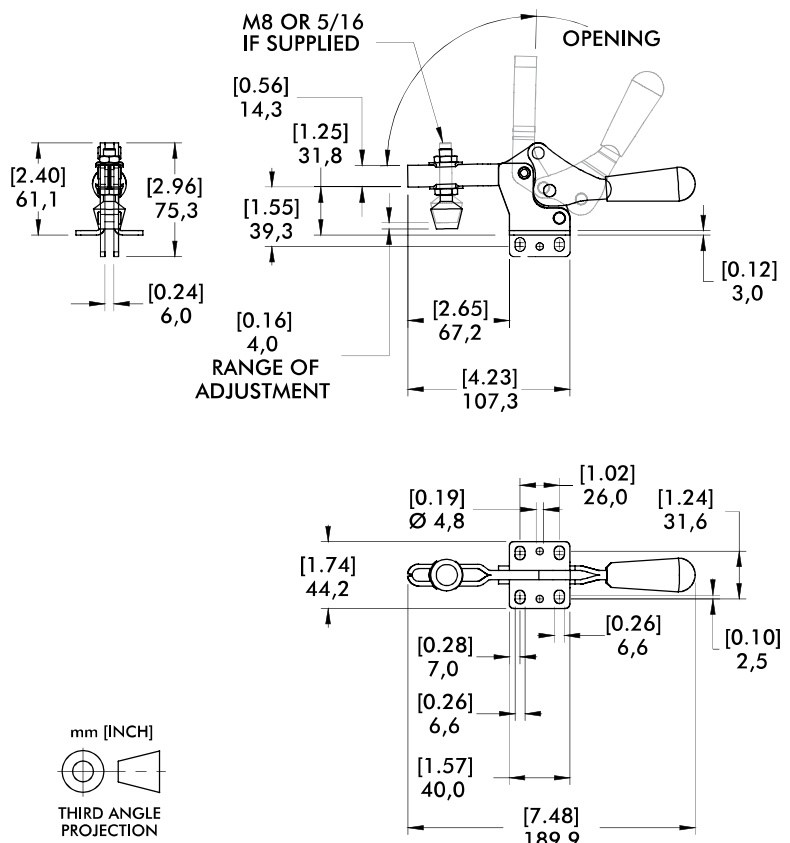

Dimensions and technical information are subject to change without notice

MC-HHD | 14



237 SERIES

Horizontal Hold Down Clamps | Product Overview

Features:

- Low profile
- Large handle clearance in the open position.
- Available in stainless steel

Applications:

- Assembly
- Checking fixtures
- Welding

Also Available:

See page MC-ACC-1 for accessories

Accommodates M10 or 3/8" spindle accessory

237-U

Flanged Base
U-Bar



237-USS ⓘ

Flanged Base
U-Bar, Stainless
Steel



Technical Information

Model	Max. Holding Capacity	Clamp Bar Opening(+10°)	Handle Opening (+10°)	Weight	Accessories (Supplied)	
					Spindle Assembly	Flanged Washers
237-U	3340 N [750 lbf]	93°	59°	0,73kg [1.60lb]	240208-M	235106
237-USS ⓘ	3780 N [850 lbf]				237943-M	235906

ⓘ This item is available upon request

Holding Capacities

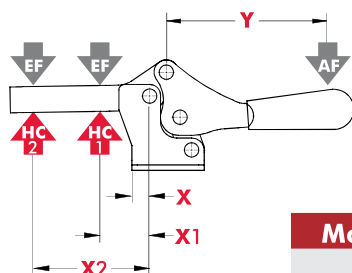

Model	X	X1	X2	Y	±HC1	±HC2	±EF(X1):AF	±EF(X2):AF
U	[0.81]	[1.75]	[4.50]	[5.25]	[750lbf.] 3340N	[290lbf.] 1290N	6:1	2:1
USS	20,6	44,5	114,3	133,3	[850lbf.] 3780N	[330lbf.] 1470N		

Dimensions shown "mm [inch]" ± HC = Holding Capacity, EF = Exerting Force, AF = Applied Force
See page MC-TEC-4 for additional information.

237 SERIES

Horizontal Hold Down Clamps | Dimensions | -U/-USS

237-U
Flanged Base
U-Bar

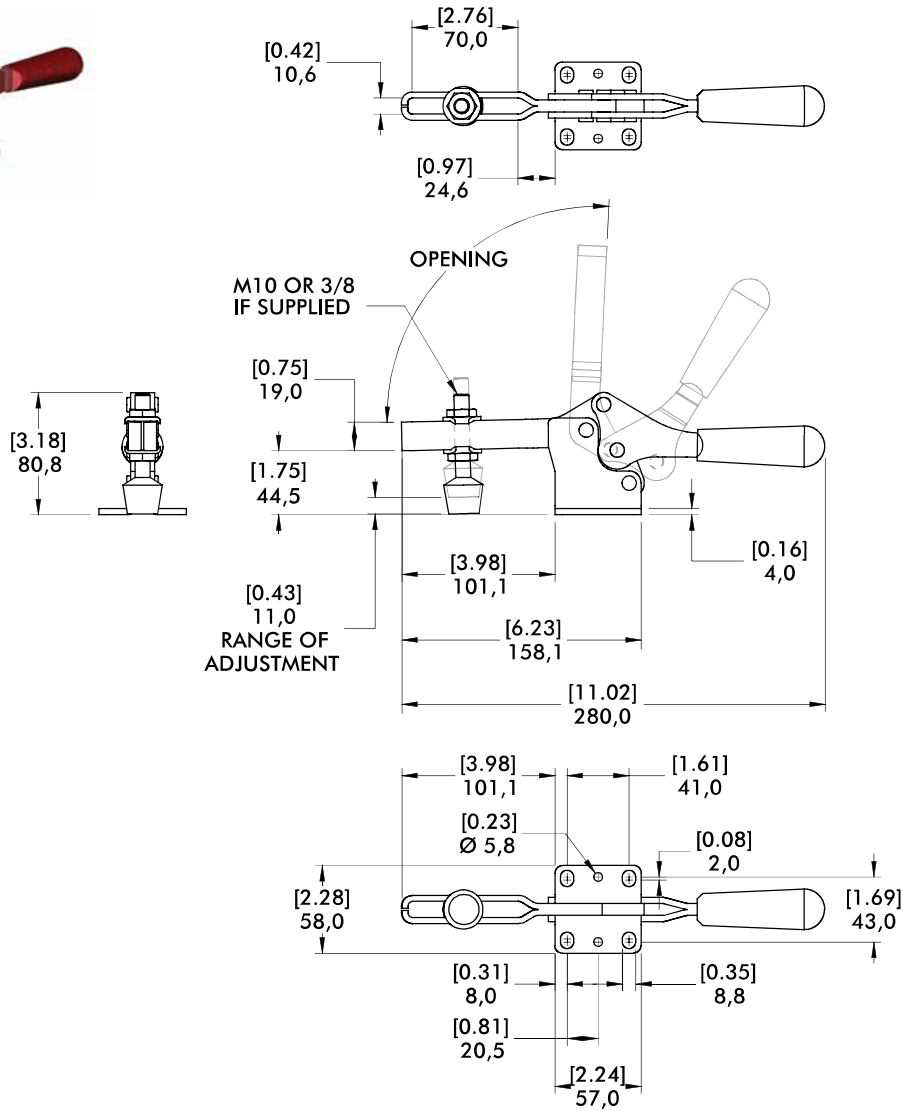

245 SERIES

Horizontal Hold Down Clamps | Product Overview

Features:

- Low profile
- Large handle clearance in the open position.

Applications:

- Assembly
- Checking fixtures
- Welding

Also Available:

See page MC-ACC-1 for accessories

Accommodates M12 or 1/2" spindle accessory

245-U

Flanged Base
U-Bar



Technical Information

Model	Max. Holding Capacity	Clamp Bar Opening (+10°)	Handle Opening (+10°)	Weight	Accessories (Supplied)	
					Spindle Assembly	Flanged Washers
245-U	4450 N [1000 lbf]	105°	74°	1,32kg [2.90lb]	247208-M	247109

Holding Capacities

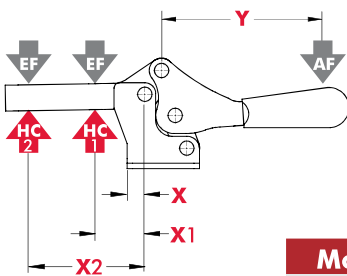

Model	X	X1	X2	Y	±HC1	±HC2	±EF(X1):AF	±EF(X2):AF
U	[0.50] 12,7	[2.00] 50,8	[5.00] 127	[6.09] 154,7	[1000lbf.] 4450N	[400lbf.] 1780N	11:1	5:1

Dimensions shown "mm [inch]" ‡ HC = Holding Capacity, EF = Exerting Force, AF = Applied Force
See page MC-TEC-4 for additional information.

245 SERIES

Horizontal Hold Down Clamps | Dimensions

245-U
Flanged Base
U-Bar

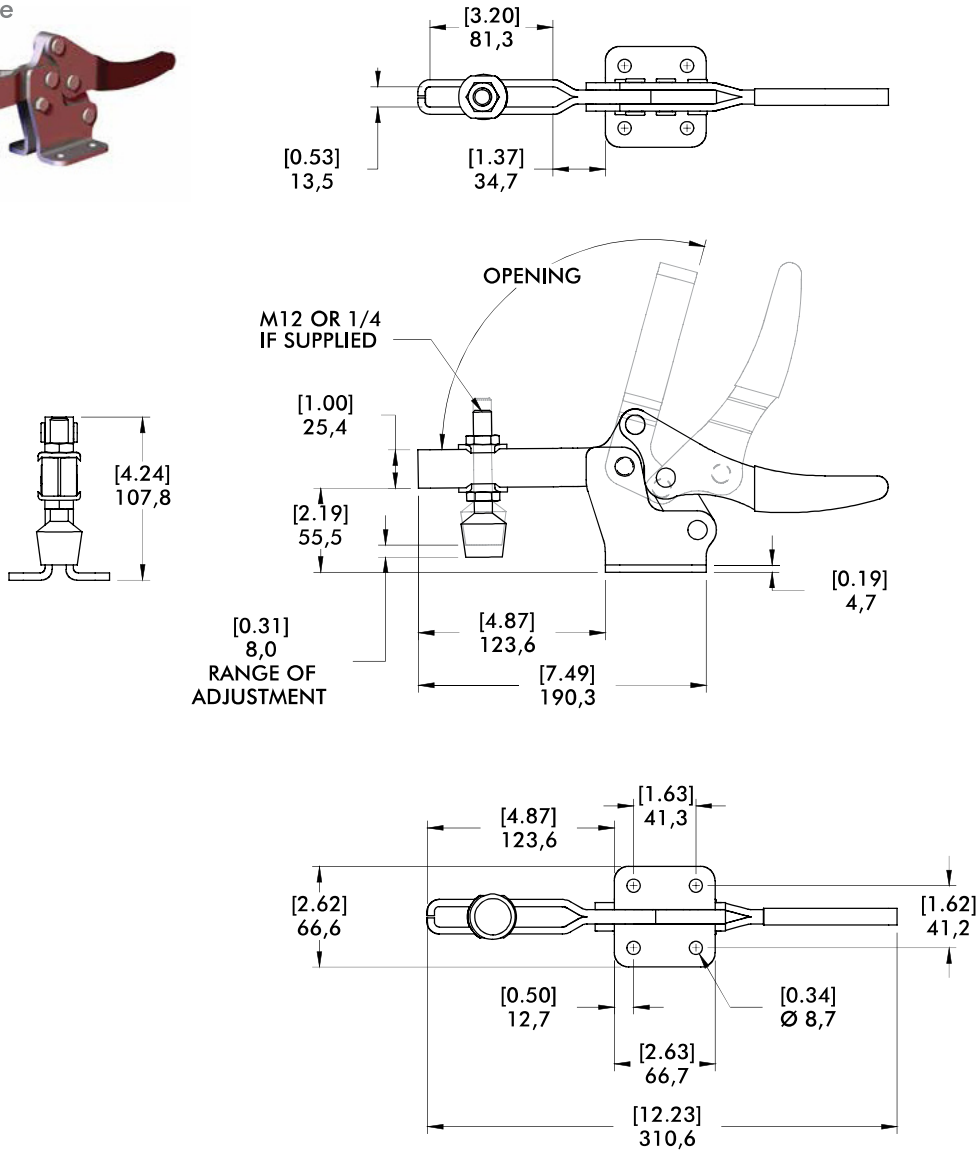

205 SERIES

Horizontal Hold Down Clamps | Product Overview

Features:

- Smallest of the Horizontal Hold Down clamps
- Ideal for light duty clamping in tight spaces
- Stainless steel models furnished without plastic grip

Applications:

- Assembly
- Closures
- Woodworking
- Light duty clamping

Also Available:

See page MC-ACC-1 for accessories

Accommodates M4 or #8 spindle accessory

205-U

Flanged Base U-Bar



205-UB ⓘ

Straight Base U-Bar



205-UL ⓘ

Left Flanged Base, U-Bar



205-UR ⓘ

Right Flanged Base, U-Bar



205-USS

Flanged Base U-Bar, Stainless Steel



205-S

Flanged Base Solid Bar



205-SB ⓘ

Straight Base Solid Bar



205-SL ⓘ

Left Flanged Base, Solid Bar



205-SR ⓘ

Right Flanged Base, Solid Bar



205-SSS

Flanged Base Solid Bar, Stainless Steel

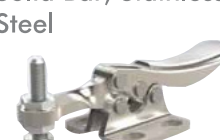

Technical Information

Model	Max. Holding Capacity	Clamp Bar Opening (+10°)	Handle Opening (+10°)	Weight	Accessories (Supplied)	
					Spindle Assembly	Flanged Washers
205-U	270N [60 lbf]	90°	80°	0,03kg [0.06lb]	205208-M	105106
205-UB ⓘ						
205-UL ⓘ						
205-UR ⓘ						
205-USS	340N [75 lbf]	94°	82°		205943-M	105906
205-S	270N [60 lbf]				205208-M	--
205-SB ⓘ						
205-SL ⓘ						
205-SR ⓘ						
205-SSS	340N [75 lbf]	205943-M				

ⓘ This item is available upon request

205 SERIES

Horizontal Hold Down Clamps | Holding Capacities

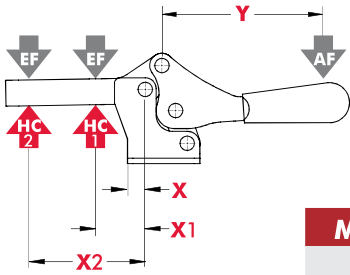

Model	X	X1	X2	Y	±HC1	±HC2	±EF(X1):AF	±EF(X2):AF
U		[0.43] 11			[60lbf.] 270N	[50lbf.] 220N	9:1	5:1
USS	[0.22] 5,6		[0.81] 20,5	[1.31] 33,2	[75lbf.] 340N	[65lbf.] 290N		
S		--			--	[60lbf.] 270N	--	4:1
SSS						[75lbf.] 340N		

Dimensions shown "mm [inch]" ± HC = Holding Capacity, EF = Exerting Force, AF = Applied Force
See page MC-TEC-4 for additional information.

Dimensions | -U/-UB/-UL-/-UR/-USS/-S/-SB/-SL/-SR/-SSS

205-U
Flanged Base
U-Bar

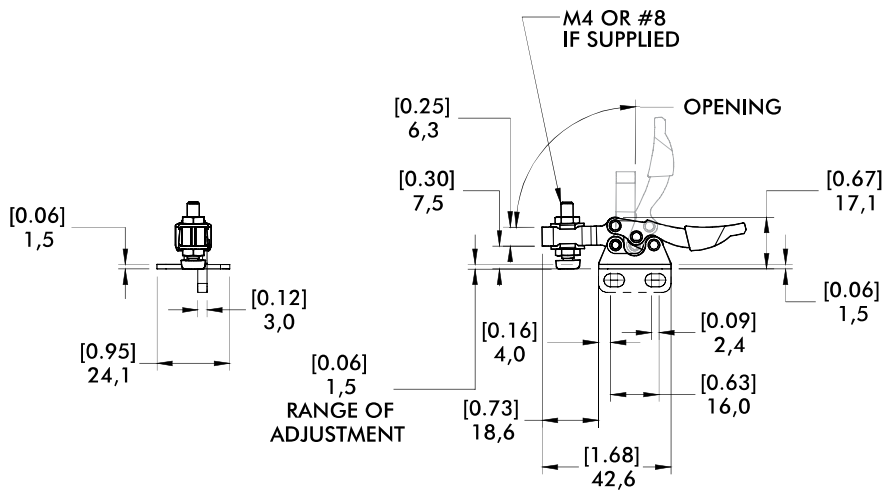
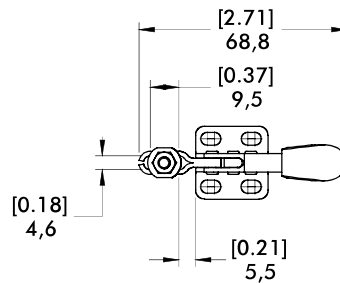

205-S
Flanged Base
Solid Bar

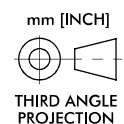
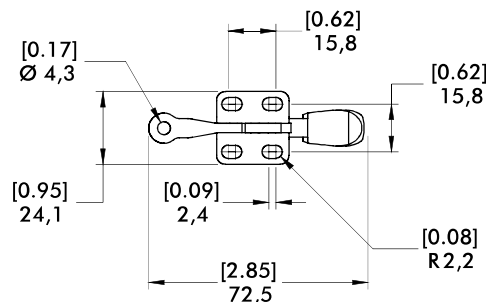

215 SERIES

Horizontal Hold Down Clamps | Product Overview

Features:

- Low profile
- Stainless steel model furnished without plastic grip

Applications:

- Assembly
- Checking fixtures
- Closures
- Woodworking

Also Available:

See page MC-ACC-1 for accessories

Accommodates M6 or 1/4" spindle accessory

215-U

Flanged Base U-Bar



215-USS

Flanged Base U-Bar, Stainless Steel



215-UB ⓘ

Straight Base U-Bar



215-S

Flanged Base Solid Bar



Technical Information

Model	Max. Holding Capacity	Clamp Bar Opening (+10°)	Handle Opening (+10°)	Weight	Accessories (Supplied)		
					Spindle Assembly	Flanged Washers	Bolt Retainer
215-U	890 N [200 lbf]	87°	78°	0,15kg [0.34lb]	202208-M	215105	--
215-USS	1110 N [250 lbf]				202943-M	215905	
215-UB ⓘ	890 N [200 lbf]				202208-M	215105	
215-S					--	--	205105

ⓘ This item is available upon request

Holding Capacities

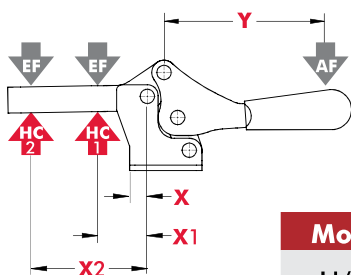

Model	X	X1	X2	Y	±HC1	±HC2	±EF(X1):AF	±EF(X2):AF
U/UB		[1.00]	[2.25]		[200lbf.] 890N	[80lbf.] 360N	9:1	4:1
USS	[0.22] 5,6	25,4	57	[2.72] 69	[250lbf.] 1110N	[110lbf.] 490N		
S		[1.63] 41,4	[2.88] 73		[200lbf.] 890N		6:1	

Dimensions shown "mm [inch]" ± HC = Holding Capacity, EF = Exerting Force, AF = Applied Force
See page MC-TEC-4 for additional information.

215 SERIES

Horizontal Hold Down Clamps | Dimensions | -U/-USS/-UB/-S

215-U
Flanged Base
U-Bar

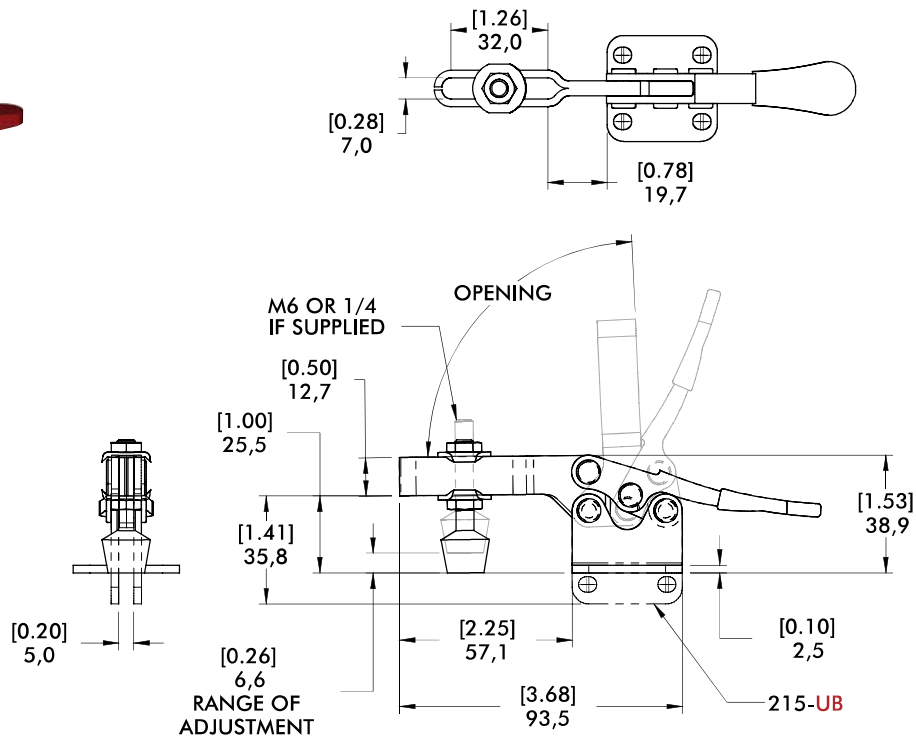

215-S
Flanged Base
Solid Bar

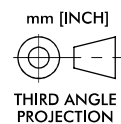
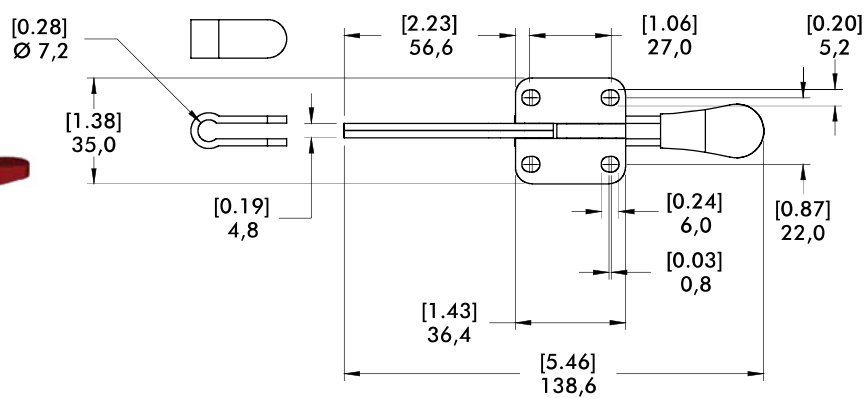
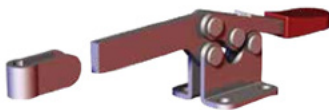

225 SERIES

Horizontal Hold Down Clamps | Product Overview

Features:

- Low profile
- Stainless steel model furnished without plastic grip
- Available with DESTACO® Toggle Lock Plus

Applications:

- Assembly
- Checking fixtures
- Closures
- Woodworking

Also Available:

See page MC-ACC-1 for accessories

Accommodates M8 or 5/16" spindle accessory

Covered under one or more U.S./International Patents

225-U

Flanged Base
U-Bar



225-USS

Flanged Base, U-Bar,
Stainless Steel



225-UR

Flanged Base, U-Bar
with DESTACO®
Toggle Lock
Plus

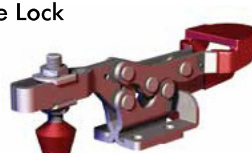

225-UB ⓘ

Straight Base
U Bar



225-UBSS ⓘ

Straight Base, U Bar,
Stainless Steel



Technical Information

Model	Max. Holding Capacity	Clamp Bar Opening (+10°)	Handle Opening (+10°)	Weight	Accessories (Supplied)	
					Spindle Assembly	Flanged Washers
225-U	2220 N [500 lbf]	92°	70°	0,25kg [0.55lb]	225208-M	507107
225-USS	2670 N [600 lbf]				207943-M	507907
225-UR	2220 N [500 lbf]			0,31kg [0.69lb]	225208-M	507107
225-UB ⓘ	2220 N [500 lbf]				207943-M	507907
225-UBSS ⓘ	2670 N [600 lbf]					

ⓘ This item is available upon request



225 SERIES

Horizontal Hold Down Clamps | Holding Capacities

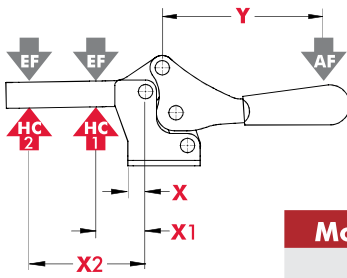

Model	X	X1	X2	Y	±HC1	±HC2	±EF(X1):AF	±EF(X2):AF
U					[500lbf.] 2220N	[250lbf.] 1110N		
USS	[0.12] 3,0	[1.25] 31,8	[2.50] 63,5	[3.56] 90,4	[600lbf.] 2760N	[300lbf.] 1340N	12:1	5:1
UR/UB					[500lbf.] 2220N	[250lbf.] 1110N		
UBSS					[600lbf.] 2760N	[300lbf.] 1340N		

Dimensions shown "mm [inch]" ± HC = Holding Capacity, EF = Exerting Force, AF = Applied Force
See page MC-TEC-4 for additional information.

Dimensions | -U/-USS/-UB/-UBSS

Dimensions | -UR

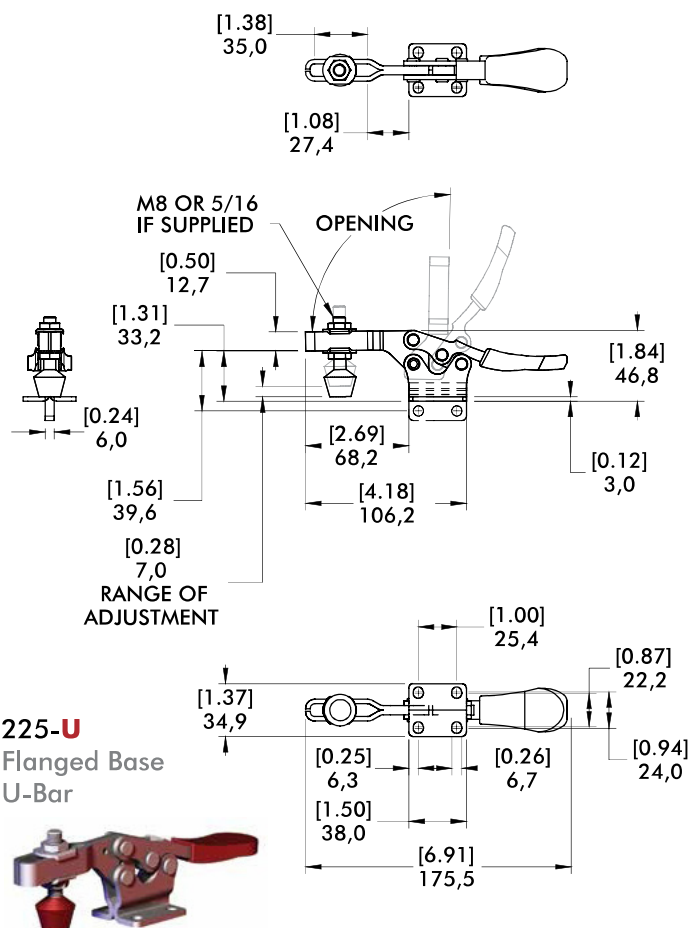

225-U
Flanged Base
U-Bar

Dimensions and technical information are subject to change without notice

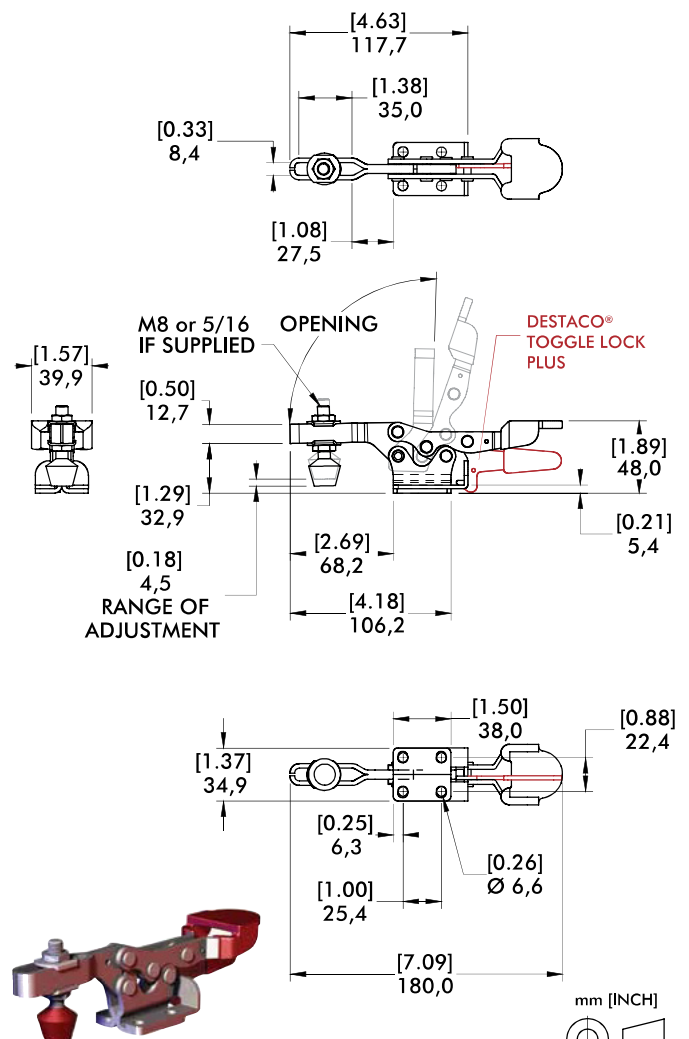

MC-HHD | 24



235 SERIES

Horizontal Hold Down Clamps | Product Overview

Features:

- Low profile
- Available with DESTACO® Toggle Lock Plus
- Available in stainless steel

Applications:

- Assembly
- Checking fixtures
- Welding
- Closures
- Woodworking

Also Available:

See page MC-ACC-1 for accessories

Accommodates M10 or 3/8" spindle accessory

Covered under one or more U.S./International Patents

235-U

Flanged Base U-Bar



235-USS

Flanged Base, U-Bar, Stainless Steel



235-UR

Flanged Base, U-Bar with DESTACO® Toggle Lock Plus



235-UB ⓘ

Straight Base U-Bar



Technical Information

Model	Max. Holding Capacity	Clamp Bar Opening (+10°)	Handle Opening (+10°)	Weight	Accessories (Supplied)	
					Spindle Assembly	Flanged Washers
235-U	3340 N [750 lbf]	92°	70°	0,67kg [1.47lb]	240208-M	235106
235-USS	3780 N [850 lbf]				237943-M	235906
235-UR	3340 N [750 lbf]			0,74kg [1.64lb]	240208-M	235106
235-UB ⓘ				0,67kg [1.47lb]		

ⓘ This item is available upon request

Holding Capacities

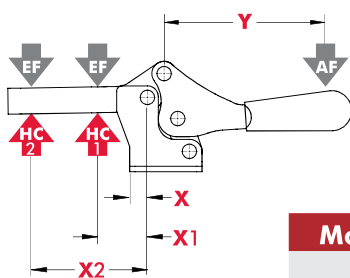

Model	X	X1	X2	Y	±HC1	±HC2	±EF(X1):AF	±EF(X2):AF
U					[750lbf.] 3340N	[300lbf.] 1330N		
USS	[0.25] 6,4	[1.75] 44,5	[4.13] 105	[5.75] 146	[850lbf.] 3780N	[360lbf.] 1600N	9:1	5:1
UR/UB					[750lbf.] 3340N	[300lbf.] 1330N		

Dimensions shown "mm [inch]" ± HC = Holding Capacity, EF = Exerting Force, AF = Applied Force
See page MC-TEC-4 for additional information.



235 SERIES

Horizontal Hold Down Clamps | Dimensions | -U/-USS-/UR-/UB

235-U Flanged Base U-Bar

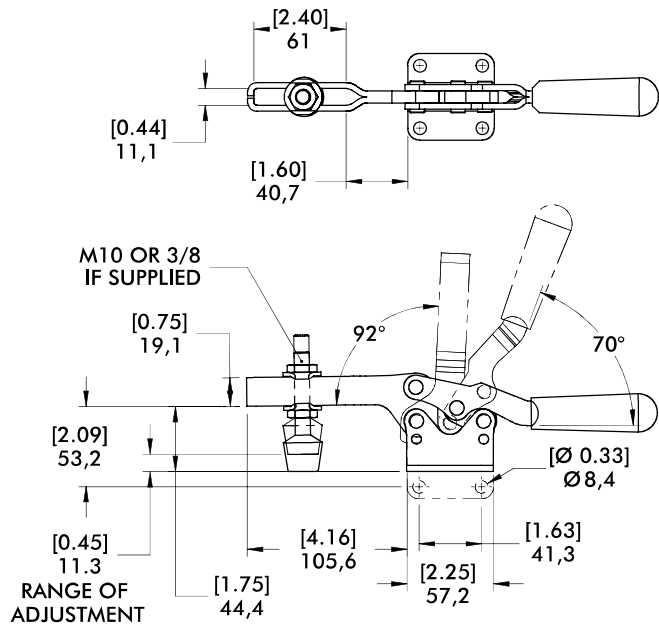
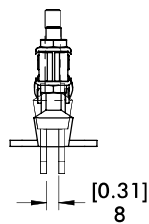

Dimensions | -UR

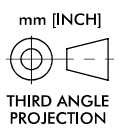
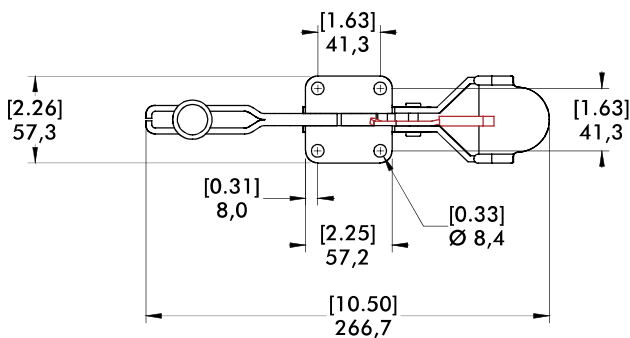
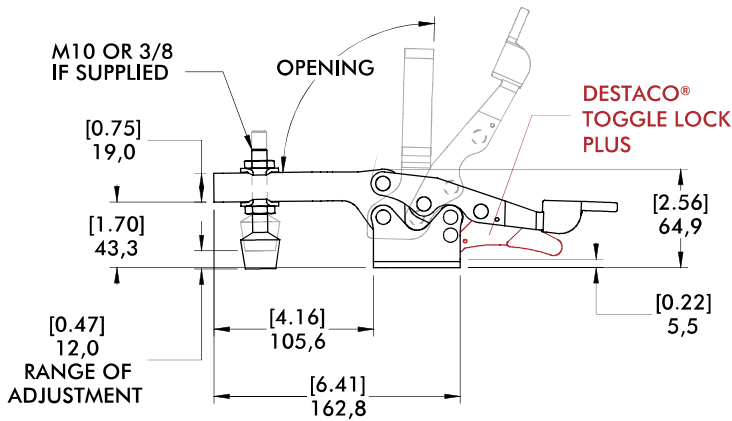
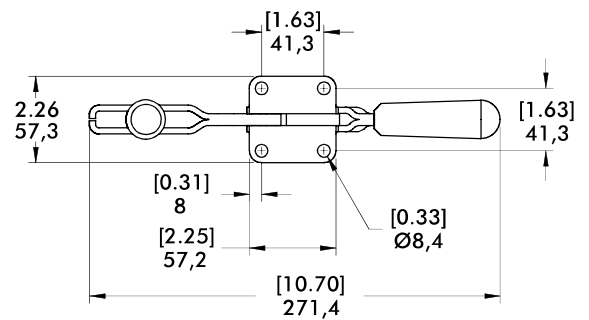
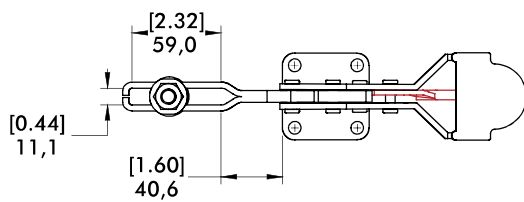

235-UR Flanged Base, U-Bar with DESTACO® Toggle Lock Plus



Dimensions and technical information are subject to change without notice

305, 307, 309 SERIES

Horizontal Hold Down Clamps | Product Overview

Features:

- Compact design suitable for use in confined spaces
- Available with DESTACO® Toggle Lock Plus™
- Stainless steel models available

Applications:

- Assembly & Test
- Light Machining
- Closures
- Woodworking

Also Available:

See page MC-ACC-1 for accessories

305-U

Flanged Base
U-Bar



305-USS

Flanged Base
U-Bar, Stainless
Steel



305-UR

Flanged Base,
U-Bar with
DESTACO®
Toggle
Lock
Plus™



305-URSS

Flanged Base,
U-Bar, Stainless
Steel with
DESTACO®
Toggle
Lock
Plus™



307-U

Flanged Base
U-Bar



307-USS

Flanged Base
U-Bar, Stainless
Steel



307-UR

Flanged Base,
U-Bar with
DESTACO®
Toggle
Lock
Plus™



309-U

Flanged Base
U-Bar



309-USS

Flanged Base
U-Bar, Stainless
Steel



309-UR ⓘ

Flanged Base,
U-Bar with
DESTACO®
Toggle
Lock
Plus™



Technical Information

Model	Max. Holding Capacity	Clamp Bar Opening (+10°)	Handle Opening (+10°)	Weight	Accessories (Supplied)	
					Spindle Assembly	Flanged Washers
305-U	670 N [150 lbf]	90°	170°	0,06kg [0.13lb]	305208-M	102111
305-USS	900 N [200 lbf]				201943-M	102911
305-UR	670 N [150 lbf]				305208-M	102111
305-URSS	900 N [200 lbf]				201943-M	102911
307-U	1560 N [350 lbf]	92°	173°	0,24kg [0.54lb]	307208-M	507107
307-USS					207943-M	507907
307-UR					307208-M	507107
309-U	3340 N [750 lbf]	90°	168°	1,30kg [0.59lb]	309208	235106
309-USS					237943-M	235906
309-UR ⓘ					309208	235106

ⓘ This item is available upon request



305, 307, 309 SERIES

Horizontal Hold Down Clamps | Holding Capacities

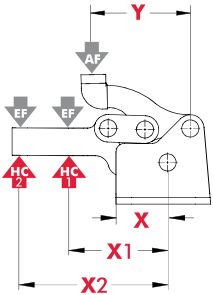

Model	X	X1	X2	Y	±HC1	±HC2	±EF(X1):AF	±EF(X2):AF
305-U/UR	[0.58]	[1.38]	[1.88]	[1.14]	[150lbf.] 670N	[110lbf.] 490N	3:1	2:1
305-USS/ 305-URSS	14,6	35	47,7	29	[200lbf.] 900N	[150lbf.] 670N		
307- U/UR/USS	[0.94]	[1.88]	[2.50]	[1.77]	[350lbf.] 1560N	[260lbf.] 1160N		
309- U/UR/USS	[1.34]	[2.50]	[3.50]	[2.70]	[750lbf.] 3340N	[530lbf.] 2360N	4:1	

Dimensions shown "mm [inch]" ± HC = Holding Capacity, EF = Exerting Force, AF = Applied Force
See page MC-TEC-4 for additional information.

Dimensions | -U/-USS/-UR/-URSS

305-U Flanged Base U-Bar

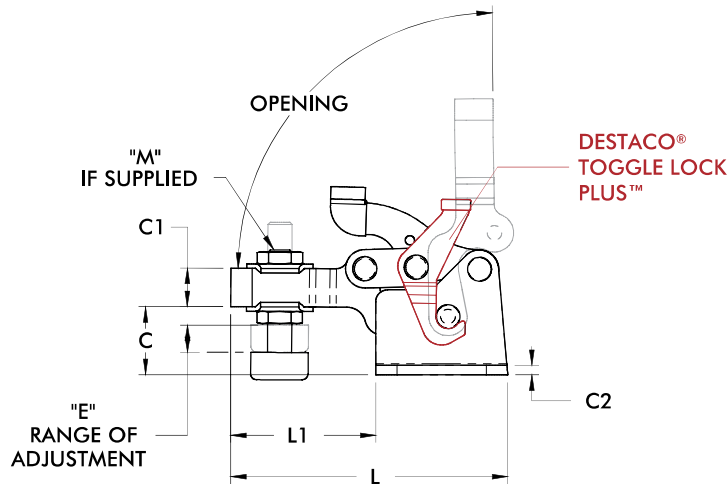
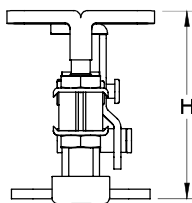
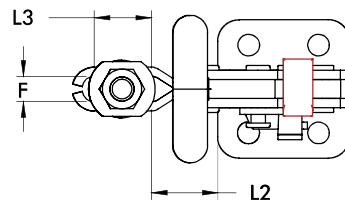

307-UR Flanged Base, U-Bar with DESTACO® Toggle Lock Plus™

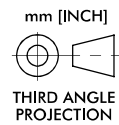
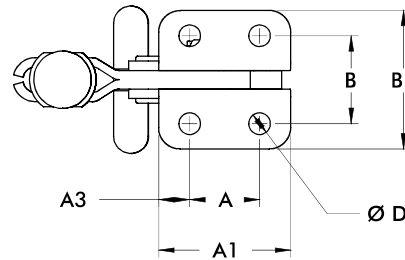

Model	A	A1	A3	B	B1	C	C1	C2	D	E	F	H	L	L1	L2	L3	M
305-U/UR	[0.53] 13,5	[1.035] 26,3	[0.25] 6,4	[0.62] 16,0	[1.02] 25,9	[0.48] 12,2	[0.31] 7,9	[0.08] 2,0	[0.18] 4,6	[0.31] 8	[0.21] 5,3	[1.43] 36,3	[2.21] 56,1	[1.19] 30,2	[0.51] 13,0	[0.50] 12,7	[#10] M5
307-U/UR	[0.91] 23,1	[1.72] 43,7	[0.40] 10,2	[1.14] 29,0	[1.80] 45,7	[0.89] 22,6	[0.50] 12,7	[0.12] 3,0	[0.28] 7,1	[0.37] 9,5	[0.33] 8,4	[2.36] 59,9	[3.61] 91,7	[1.89] 48,0	[0.86] 21,8	[0.75] 19,1	[5/16] M8
309-U/UR	[1.38] 35,1	[2.52] 64,0	[0.58] 14,7	[1.50] 38,1	[2.47] 62,7	[1.31] 33,3	[0.75] 19,1	[0.12] 3,0	[0.33] 8,4	[0.72] 18,5	[0.44] 10,4	[3.53] 89,7	[5.19] 131,8	[2.68] 68,1	[1.28] 32,5	[1.06] 26,9	[3/8-16] M10

Dimensions and technical information are subject to change without notice

MC-HHD | 28



206 SERIES

Horizontal Hold Down Clamps | Product Overview

Features:

- All stainless steel construction
- Offers good bar clearance under clamping bar while maintaining low profile

Applications:

- Assembly
- Chemical processing
- Closures
- Light duty clamping

Also Available:

See page MC-ACC-1 for accessories

Accommodates M4 or #8 spindle accessory

206-SS

Flanged Base
Low U-Bar,
Stainless Steel



206-HSS

Flanged Base
High U-Bar,
Stainless Steel



Technical Information

Model	Max. Holding Capacity	Clamp Bar Opening (+10°)	Handle Opening (+10°)	Weight	Accessories (Supplied)	
					Spindle Assembly	Flanged Washers
206-SS	440 N [100 lbf]	90°	90°	0,03kg [0.07lb]	205943-M	105906
206-HSS						

Model 206-HSS shown securing a platen on a prototyping machine.



206 SERIES

Horizontal Hold Down Clamps | Holding Capacities

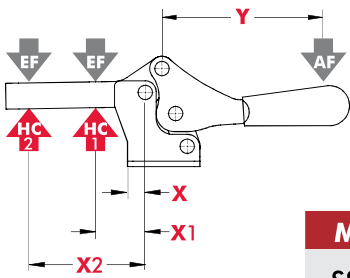

Model	X	X1	X2	Y	±HC1	±HC2	±EF(X1):AF	±EF(X2):AF
SS/HSS	[0.20] 5	[0.43] 11	[1.06] 27	[1.14] 29	[100lbf.] 440N	[50lbf.] 220N	5:1	3:1

Dimensions shown "mm [inch]" ± HC = Holding Capacity, EF = Exerting Force, AF = Applied Force
See page MC-TEC-4 for additional information.

Dimensions | -SS/-HSS

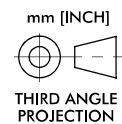
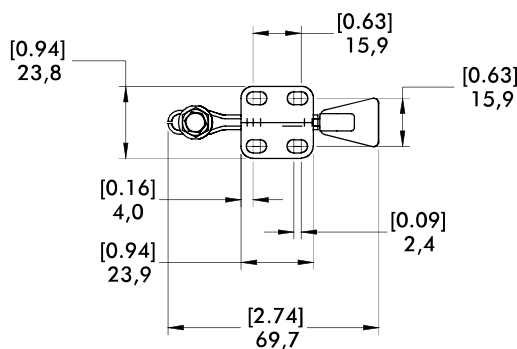
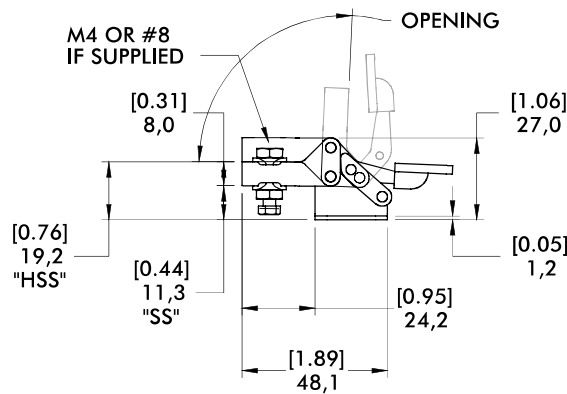
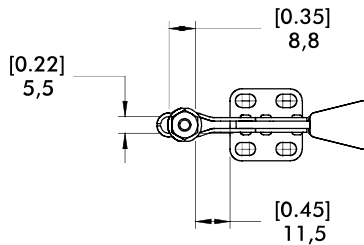

5305, 5310 SERIES

Heavy Duty Horizontal Hold Down Clamps | Product Overview

Features:

- Solid clamping arm may be modified to suit requirements
- Hardened steel pivot pins and bushings provide long life
- Black oxide finish
- DESTACO® Toggle Lock Plus versions available†

Applications:

- Welding fixtures
- Assembly fixtures
- Light machining



5305/5310
Flanged Base



5305-B/5310-B
Solid Base



5305-R/5310-R
Flanged Base with DESTACO® Toggle Lock Plus



5305-BR†/5310-BR†
Solid Base with DESTACO® Toggle Lock Plus



Technical Information

Model	Max. Holding Capacity	Clamp Bar Opening (+10°)	Handle Opening (+10°)	Weight
5305	[600lbf.] 2670N	90°	69°	[1.08lbs] 0,49kg
5305-B				[0.82lbs] 0,37kg
5305-R				[1.09lbs] 0,49kg
5305-BR†				[0.83lbs] 0,37kg
5310	[1300lbf.] 5780N	90°	69°	[2.84lbs] 1,29kg
5310-B				[2.24lbs] 1,02kg
5310-R				[2.87lbs] 1,30kg
5310-BR†				[2.27lbs] 1,03kg

† This item is available upon request.

† Toggle Lock Plus locks the handle in the closed position only.

5305, 5310 SERIES

Heavy Duty Horizontal Hold Down Clamps | Dimensions

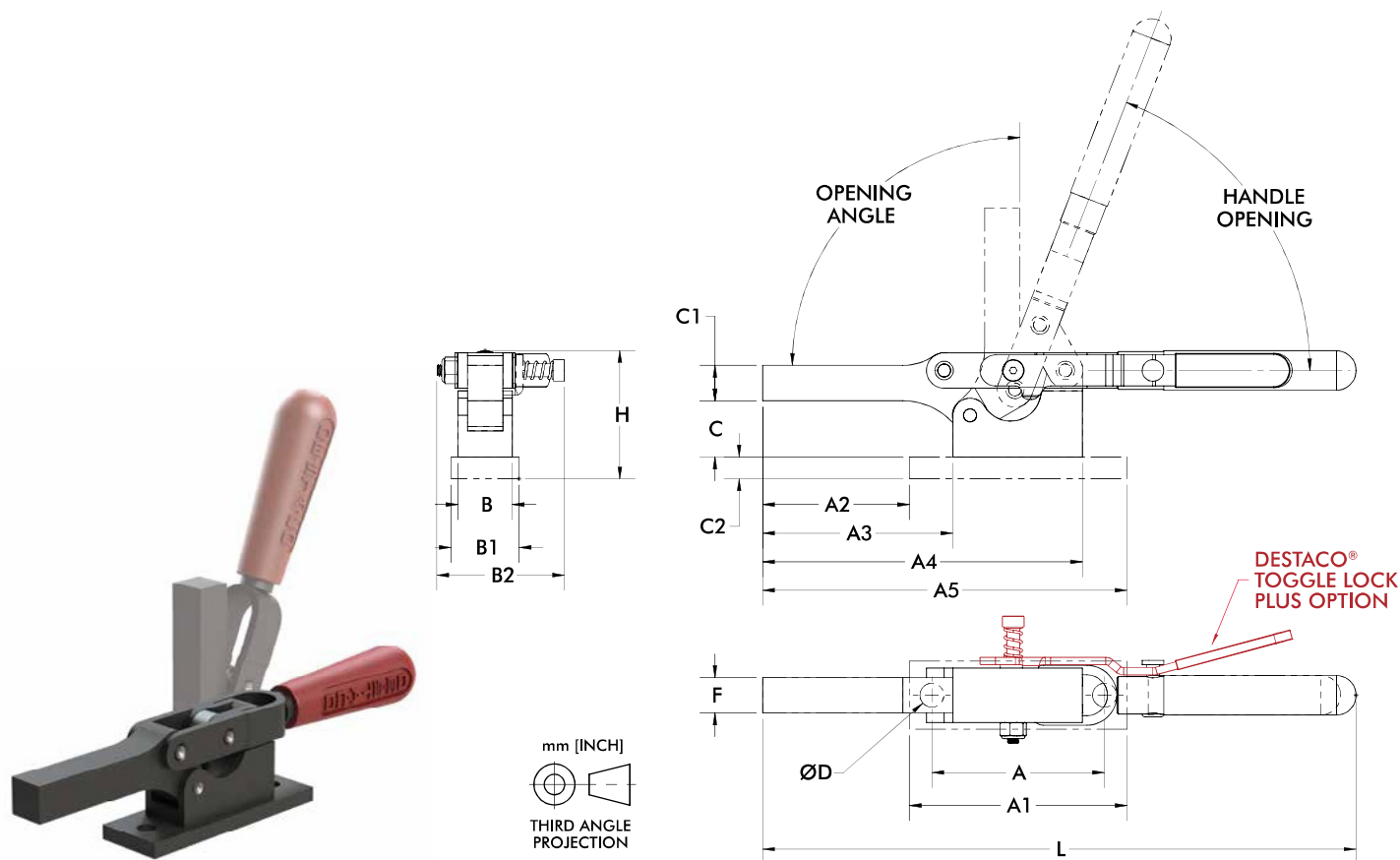

Model	A	A1	A2	A3	A4	A5	B	B1	B2	C	C1	C2	D	F	H	L
5305	[2.50]	[3.15]	[2.12]	[2.75]	[4.63]	[5.27]	[0.79]	[0.98]	--	[0.81]	[0.51]	[0.31]	[0.35]	[0.51]	[1.51]	[8.36]
5305-R	63,5	80,0	53,8	69,9	117,6	133,9	20,1	24,9	[1.84] 46,7	20,6	13,0	7,9	8,9	13,0	38,4	212,4
5310	[3.63]	[4.63]	[2.63]	[3.63]	[6.25]	[7.25]	[1.13]	[1.50]	--	[1.00]	[0.75]	[0.31]	[0.41]	[0.79]	[2.00]	[11.13] 282,6
5310-R	92,2	117,6	66,8	92,2	158,8	184,2	28,7	38,1	[2.31] 58,7	25,4	19,1	7,9	10,4	20,1	50,8	[11.02] 279,8

Model	A3	A4	B2	C	C1	F	H	L
5305-B	[2.75]	[4.63]	--	[0.81]	[0.51]	[0.51]	[1.51]	[8.36]
5305-BR ^①	69,9	117,6	[1.84] 46,7	20,6	13,0	13,0	38,4	212,4
5310-B	[3.63]	[6.25]	--	[1.00]	[0.75]	[0.79]	[2.00]	[11.13] 282,6
5310-BR ^①	92,2	158,8	[2.31] 58,7	25,4	19,1	20,1	50,8	[11.02] 279,8

^① This item is available upon request